

Explosion Isolation Flap Valve CARZ-NS - protective system

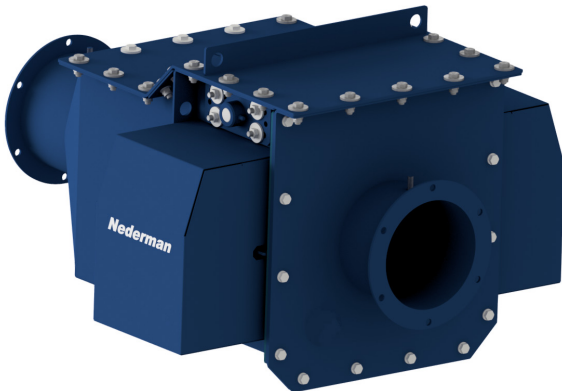
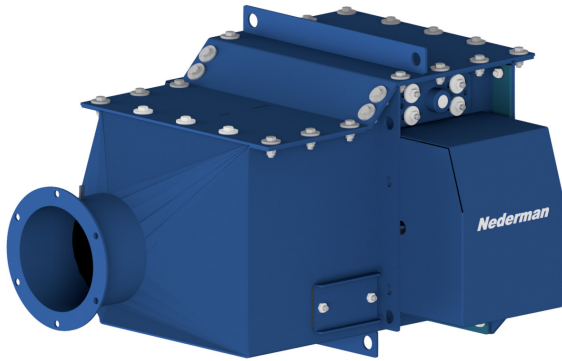

PATENTED PRODUCT

Patent protected product:

- EP patent: EP 3 343 077
- USA: US 10 315 059
- China: 201711349554.2

Marking



The marking is based on product certification:

- FTZÚ 18 ATEX 0147X by N.B. No. 1026 and Quality System approval by N.B.

Explosion Isolation Flap Valve type CARZ-NS is designed as an explosion pressure resistance equipment, which is able to prevent the transmission of dangerous effects from an explosion pressure wave and flame front to upstream areas. Certified according to EN 16447.

Description

Welded construction in RAL 5009 blue painted steel plate.

Function

During airflow generated by main fan, the Flap plate is open. In case of an explosion in the downstream equipment (e.g. dust collector) a pressure wave will force the Flap plate to close and lock in position. Large opening angle ensures low pressure drop. When Flap plate is closed it makes an effective barrier against approaching flame front. This prevents the explosion from being transmitted to upstream work areas, protecting workers, machinery and the facility.

Suction direction

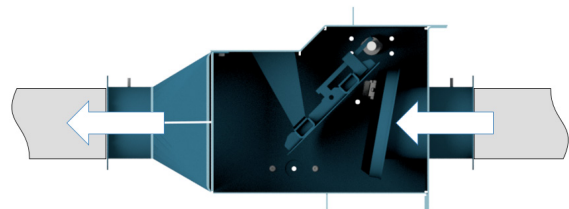

Explosion direction



Special installation requirements

PULL configuration

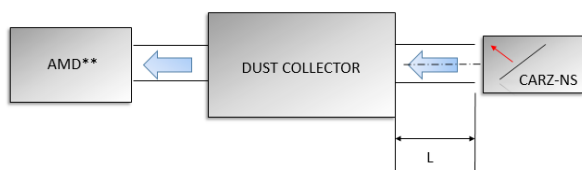

PUSH configuration

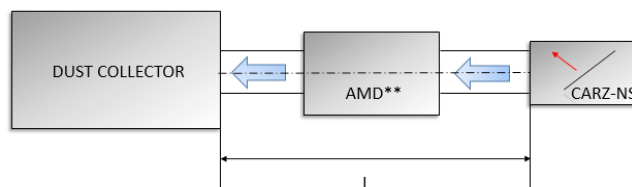
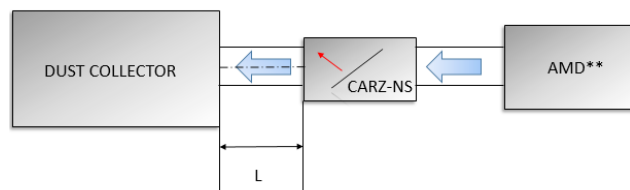

**AMD=Air moving device or fan

Parameter	Size: 160 -250 mm
L min	5 m
L max	10 m
Max. flow velocity	35 m · s ⁻¹
Max. number of bends (between CARZ-NS and protected vessel)	straight duct with max. 2 elbows 90 dgr

Specifications

Combustible dust properties	PULL	PUSH
	Size: 160 - 250 mm	
Explosion class	St2	
Kst	Kst ≤ 300 bar · m · s ⁻¹ for organic Kst ≤ 260 bar · m · s ⁻¹ for metallic	Kst ≤ 300 bar · m · s ⁻¹ for organic
MESG*	≥ 1.3 mm	

* Maximum Experimental Safe Gap.

For dust MESG (mm) is calculated from MIE (mJ) and MIT (°C) using the following equation (Eckhoff, 2003):**

$$MESG = 1,01 \times (MIE \times (MIT + 273) / 273) ^ 0,157$$

** Reference to EN 16447:2014, chapter 5.2.3.

Parameters	PULL	PUSH
	Size: 160 - 250 mm	
Operating temperature range*	-20°C to +60°C	
Ambient Temperature		
Max. explosion reduced pressure in vessel - p _{red, max}	50 kPa	
Max. dust concentrations in duct	Any for organic < LEL** for metallic	Any for organic
Min. Vessel size	0,46 m ³	
Explosion shock resistant pressure in CARZ-NS	1 bar	
Inclination of the CARZ-NS	Horizontally	
Protection method of connected vessel	Any including suppression and self-closing vents for organic Non-self-closing vents only for metallic	Any including suppression and self-closing vents for organic

*Intake air temperature.

** Lower explosion limit.

Dimensions

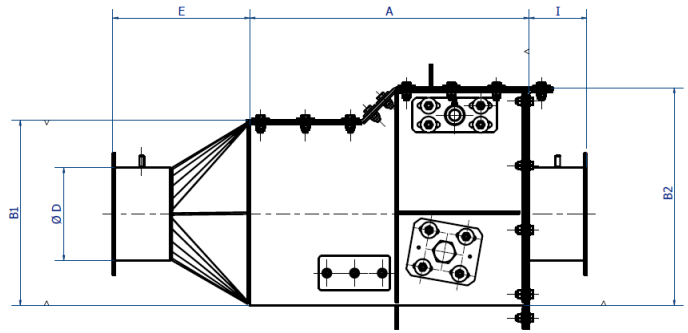
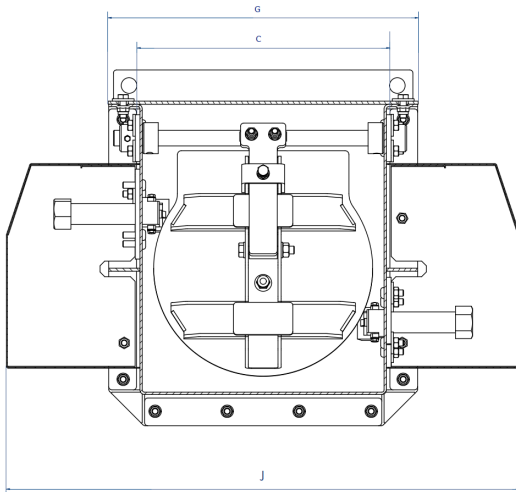

CARZ-NS size	A	B1	B2	C	E	G	I	J	Weight	Part number			
										FL	QF	NW	
	mm									kg			
160	484	320	376	316	238	396	100	660	50	73008218	73008219	73008220	
180	484	340	397	339	238	420	100	682	54	73008398	73008399	73008400	
200	506	355	413	351	238	431	100	694	56	73008401	73008402	73008403	
250	579	399	449	396	238	476	100	727	62	73008404	73008405	73008406	

FL - bolted flange,

QF - flange for Quick Fittings type ducting system,

NW - bolted flange according to standard DIN 24154-R2.

Chart of pressure drop vs. velocity

CARZ-NS 160 - 250 mm: Static Pressure

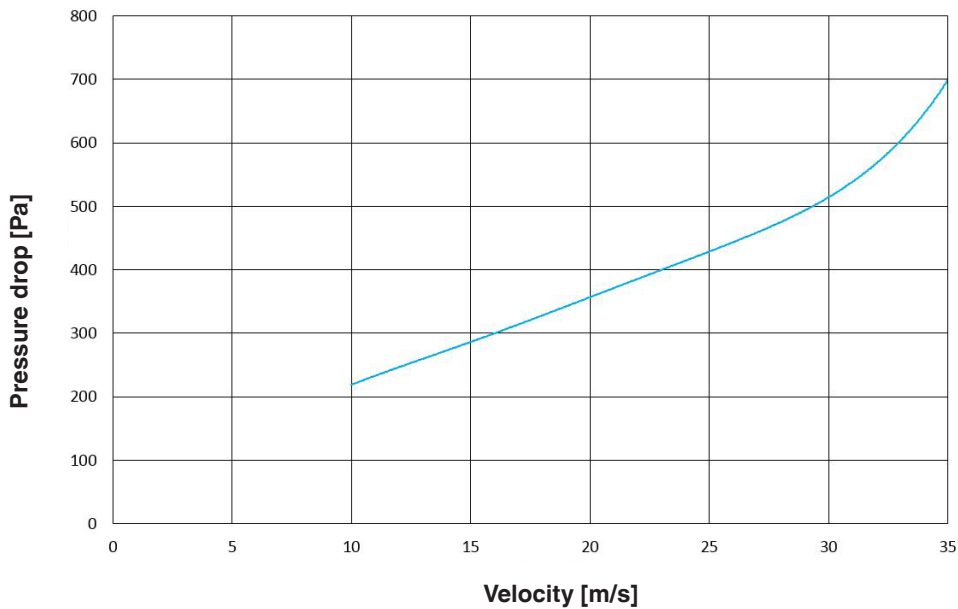

Accessories

Manufacturer offers accessories that must be ordered separately:

- Flap lock indicator II 2 D-Ex tb IIIC T85°C Db, IP66/67 - part number: **73007978**.
- Flap lock indicator not for an external explosive atmosphere - part number: **73007979**.

Contact Nederman for other configurations with dust build-up sensor for NFPA 69 compliance.