

## Waste oil rail

Flexible waste oil rail with cleanable filter for long lifetime. The covered rail secures a healthier and safer working environment in your vehicle service center.



Nederman Waste oil rail is a well covered rail prepared for ventilation to avoid odours in grease pits. High flow funnel and arms secure against spillage, and is easily adjustable. The rail is mounted with a small incline along the work pit, which makes the waste oil automatically flow to the end of the rail where it is temporarily stored in an 80 litre tank with filter and pump control. The waste oil can then either be drained or be pumped into a central waste oil tank.













When the system is not in use, the arm unit can be positioned out of the way along the pit wall thanks to the swivelling arm and the adjustable height of the collection bowl. The rail can have either one or more trolley/arm units.

- The covered rail prepared for ventilation improves the health and safety for personnel - avoiding odour and cancerogenic fumes.
- The adjustable high flow funnel and arm is flexible, ergonomic and easy to move into right position to prevent spillage, thereby securing a safer work environment.
- The flexible arm is easy to stow away to make space in the pit, when not used.
- Intermediate tank with cleanable filter secures long lifetime of filter and optimized operation of the pump.

Product name	Waste oil rail
Installation	[Indoor]
Material	Aluminium rail, plastic tank and steel arm and bowl
Ambient temperature range	-10 to +50 C (14 F to 122 F)
Further technical data	Oil temperature: max 90 °C



## Waste oil rail

Image	Description	Weight (kg)	Model
	Waste oil rail 2,5m complete	7,5 kg/m (incl brackets)	30583405
	Waste oil rail 5,0m complete	7,5 kg/m (incl brackets)	30583406
	Waste oil rail 7,5m complete	7,5 kg/m (incl brackets)	30583407
	Waste oil rail 10m complete	7,5 kg/m (incl brackets)	30583408
	Waste oil rail 12,5m complete	7,5 kg/m (incl brackets)	30583409
	Waste oil rail 15m complete	7,5 kg/m (incl brackets)	30583410
	Waste oil rail 17,5m complete	7,5 kg/m (incl brackets)	30583411
	Waste oil rail 20m complete	7,5 kg/m (incl brackets)	30583412
	Waste oil rail 22,5m complete	7,5 kg/m (incl brackets)	30583413
	Waste oil rail 25m complete	7,5 kg/m (incl brackets)	30583414
	Collector tank including filter	11	30583404
	Pump control complete, waste oil	1,3	30583403

## Waste oil rail

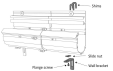
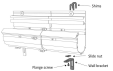
Accessory		Part No
	Filter carpet	30594750
	Wall shim kit	30377271

# Waste oil rail

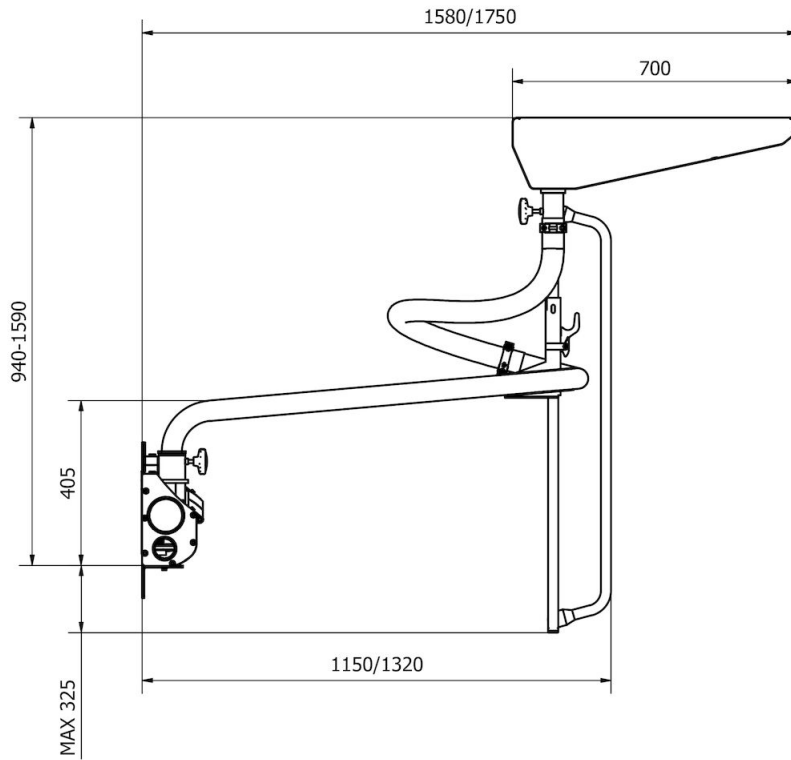

# Waste oil rail

