



Nederman



The S-Series

Simple, Silent and Safe
Enclosureless Dust Collector

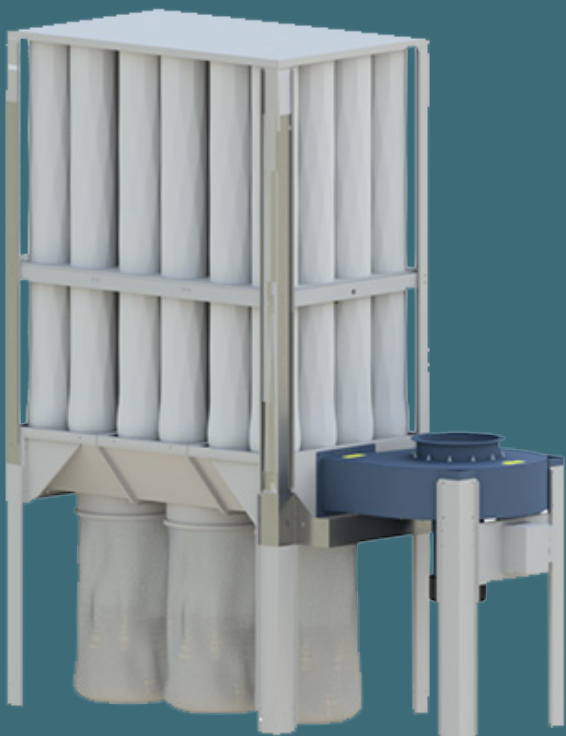

Simple, Silent & Safe Dust Collection

Nederman is The Clean Air Company and the S-Series is a turn-key dust collection solution for industrial applications including woodworking.



Reliable and Effective Indoor Filtration

The S-Series is an enclosureless, silent and simple to set up dust collector suitable for wood and sawdust applications (furniture, cabinetry, windows, doors, flooring, particle board, MDF, building materials, marine, and sawmills) and for general dust collection where feasible.

It is designed for indoor installation compliant with NFPA combustible dust regulations. They are available in three sizes: the S-500, S-750 and S-1000 ranging from 1,500 - 5,000 CFM, providing a cost-effective filtration solution for small and medium-sized workshops.

Features:

- Designed for Indoor Installation
- NFPA Compliant
- SuperBag Technology (99.9% Efficiency)
- Easy Installation
- Quiet & Simple Operation
- Low Energy Consumption
- Small Footprint
- Available Shaker Cleaner Option
- Multiple Waste Collection Options - Bags, Barrels or Bin



Applications:

- High-Speed Routing
- Sawing & Cutting
- Single-Cell Manufacturing
- After-Filters

Applying the S-Series

Enclosureless dust collectors like the S-Series offer a convenient and effective solution for combustible dust applications within the woodworking and manufacturing industries but are subject to several important application constraints when handling combustible dusts. The S-Series maximum airflow is limited to 5,000 CFM (8,500 m³/hr) and they are not recommended for sanders, molders, or abrasive planes having mechanical feeds as well as cannot be used to vent or serve metal grinding, hot work processes, and machinery that can generate or produce sparks. For safe use, maintenance protocols including filter cleaning and waste removal outlined within the NFPA standards and Nederman manuals must be strictly followed.

Nederman is a global leader for NFPA and ATEX compliant dust collection solutions. Our comprehensive approach throughout the design, application, installation and maintenance sets us apart in providing complete and compliant solutions. Nederman is the global leader for ATEX and NFPA compliant dust collection solutions. Our comprehensive approach throughout the design, installation and maintenance processes sets us apart to provide a complete, safe and compliant solution.

Long-Lasting, Effective, Easy to Use

Designed for longevity and minimizing operational cost. Our highly efficient, quiet running radial fans are designed to transfer high concentrations of wood dust and chips.

- **Reduced Maintenance Cost** - Built with high performance Superbags reducing your routine bag replacement needs down to 3-5 years with longer bag life depending on the dust particle size.
- **Reduced Noise Level** - High performance fans run 10-15 dB(A) over normal conversation sound levels, 70 - 75 dB(A) @ 10 in.w.g
- **Higher Productivity** - Lower filter resistance, highly efficient fans and interlocked design allows for greater and more consistent suction.
- **Bag Replacement Without Any Tool** - Heavy-duty plastic collection bags are connected with Quick-Fit clamps allowing for tool-less removal and installation.

SUPERBAG Filters - The Heart of the System

The Nederman SUPERBAG technology delivers high efficiency, low energy consumption, combustible dust safety and extended life.

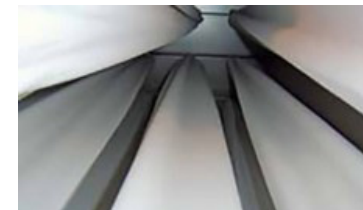

- Achieve recommended dust emission levels and improved ambient air
- Low pressure drop requires less energy
- Durable construction with seamless, woven construction
- Reduced risk of fire and explosion with anti-static woven carbon fibers

NFPA Compliant, Safe and Reliable Solution

S-Series dust collectors provide a safe and reliable solution to combustible dust compliance in accordance with the latest NFPA standards when properly applied and maintained. For full NFPA compliance with combustible dust applications including woodworking, owner/operator must install and operate the collector in accordance with the requirement for enclosureless dust collectors as outlined within the following standards.

- **NFPA 654:** Standard for the prevention of fire and dust explosions from the manufacturing, processing and handling of combustible particulate solids [Chapter 9.3.13.1.1.2 (4)]
- **NFPA 664:** Standard for the prevention of fires and explosions in wood processing and woodworking facilities [Chapter 9.3.4 (7)]

The owner/operator is responsible for compliance with all applicable federal, state and local codes. NFPA standards are available at NFPA.org.



Fast, Efficient & Effective



Quick and Easy Installation

The unique collapsible design provides compact shipping and ease of installation. Fan and SuperBags are pre-installed further minimizing installation time and effort. Installation is completed in three simple steps:

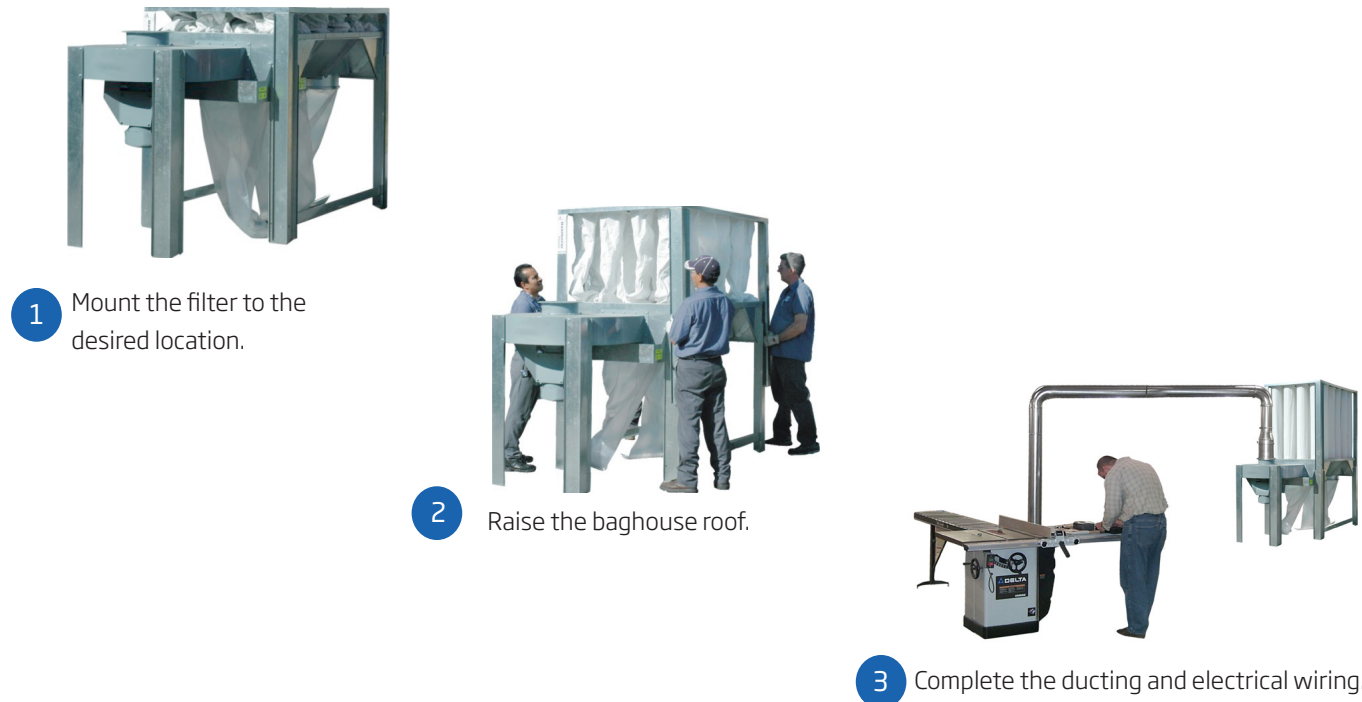

How it Works

During normal operation:

- 1 Dust laden air from the plant travels down the supply duct
- 2 Dirty air then enters the COMBIFAB material handling fan
- 3 Dust then enters the hopper section of the filter
- 4 As air slows down within the hopper, the heavier dust particles fall down into the inside of the collection bags
- 5 The remaining dust then travels up into the inside of the filter bag.
- 6 The air, which originated from the plant, is now clean and passes through the filter bag into the surrounding atmosphere.

While cleaning:

- 1 The S-Series may only clean "off-line", when the COMBIFAB fan has stopped rotating
- 2 The S-Series is cleaned by applying physical force to the outside of the filter bag which in effect, shakes them off
- 3 The dust cake, which hangs on the inside of the filter bag falls into the hopper section and then into the collection bags below



World's Fastest Industrial Ducting

Simple to install for faster installation the clamp together components can be taken apart and reused. It is easy to connect to existing duct work and the components make it fit every system. Also with adjustable QF fittings it simplifies duct connections, with smooth interior surfaces it helps prevent blockages.

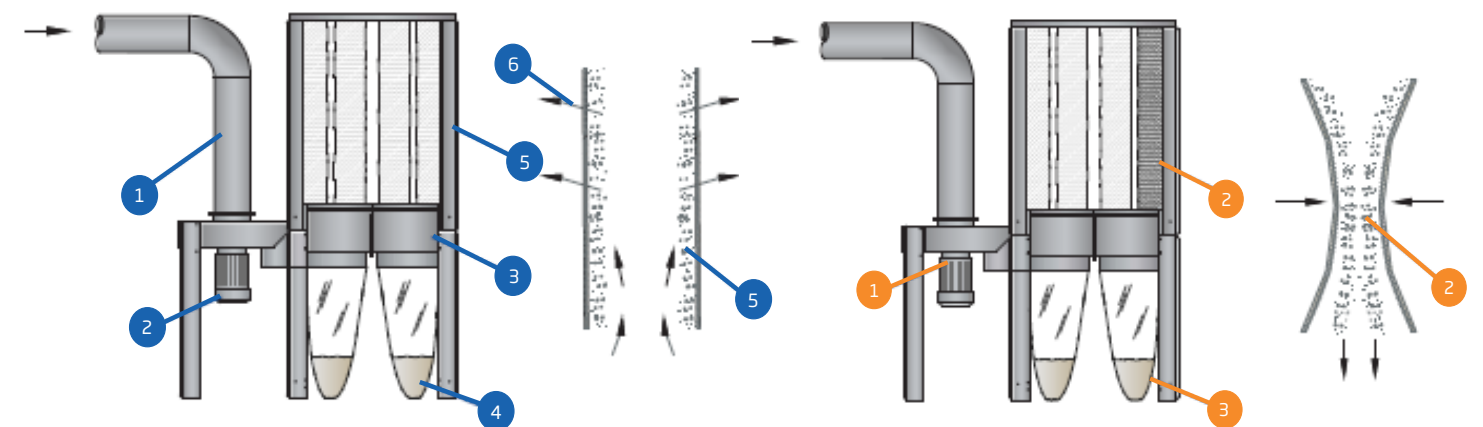

Dust Collection for Your Needs



Technical Specifications

The S-Series filters are available in three different sizes equipped with three different fans with TEFC motors. Filter model is selected based upon the amount and type of material being collected and the total extracted air volume required.

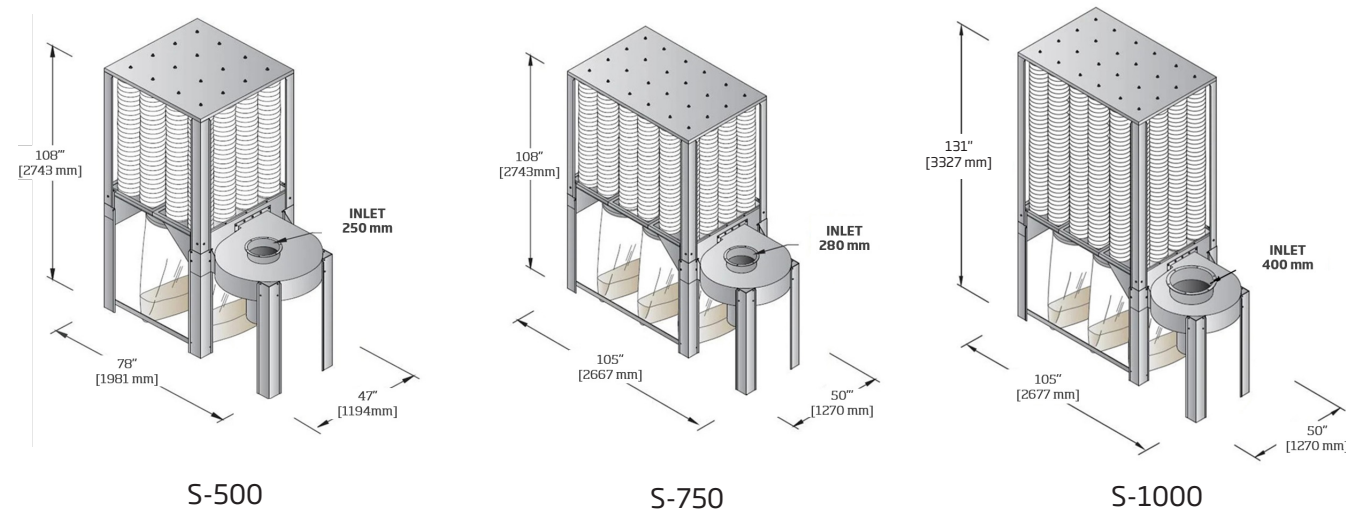

S-Series Model	Pressure Drop	Design Airflow Capacity	Motor Power	Total Filtration Area	Bag Quantity		Number of Waste Discharge Ports & Clamps	Shipping Weight
	in. w.g (Pa)	CFM (m ³ /h)	HP	ft ² (m ²)	Superbag Filter Bags	Plastic Waste Bags		lbs. (kg)
S-500	5.0 (1,245)	3,000 (5,097)	5	162 (15)	16	2	2	880 (399)
	7.5 (1,868)	2,000 (3,398)						
	8.0 (1,993)	1,500 (2,549)						
S-750	6.0 (1,495)	4,500 (7,646)	7.5	243 (22.6)	24	3	3	1100 (499)
	8.0 (1,993)	3,500 (5,947)						
	10.0 (2,490)	2,500 (4,248)						
S-1000	7.0 (1,744)	5,000 (8,495)	10	360 (33.45)	24	3	3	1160 (526)
	8.0 (1,993)	4,000 (6,796)						

Additional Notes:

- Available with optional aluminum impellers
- Can be used as an afterfilter without fan
- Motors are TEFC and operate at 1760 RPM
- Support structure is galvanized steel construction
- Supply voltages are available in Single Phase 208V or 230V / 60Hz (S-500 only) , 3 Phase 208-230/460V/60 Hz or 575V/60 Hz

Waste Disposal Options

The S-Series filters waste disposal is handled with plastic waste bags as standard. As an option, the waste disposal can be handled with total 45 gal (170 L)* capacity barrels and 230 gal (871 L) capacity dump bins.



Bags (standard)

*42 gal (159 L) working volume



Barrels (optional)

45 gallons /170 L*



Dump bin (optional on S-750 & S-1000)

230 gallons / 871 L

Dump Bin Upgrade Saves Production Time.

- Increase capacity by 80% compared to bags
- Simple quick clamp for easy and clean maintenance
- Easy forklift removal for worker safety
- Easy "tilt-to-empty" design for simple waste disposal



Enhanced Cleaning, Safer Maintenance & Lower Costs



S-Shaker Upgrade Now Available

S-Series dust collectors are now available with a shaker filter cleaning option that improves system performance and simplifies maintenance. The shaker mechanism cleans the filters more consistently and effectively than traditional manual cleaning techniques resulting in greater machine suction, extended filter life and improved operational safety.

The shaker kit is available for new equipment or field retrofits on existing equipment and is available with a manual, mechanical or automatic actuator. The shaker option is ideal for heavy loading applications including fine wood or sawdust, plastic or paper dust applications.

How Does it Work?

A shaker plate is installed on the dust collector frame with the filter bags threaded through the circular openings.

There are three available actuator control options that initiate the shaker mechanism to clean the bags.



Manual - A handle attached to the shaker plate is manually moved back and forth.



Mechanical - A push-button switch actuates a pneumatic cylinder attached to the shaker plate.



Automatic - Upon fan shut-down, a cleaning sequence is initiated with a pneumatic cylinder attached to the shaker plate.

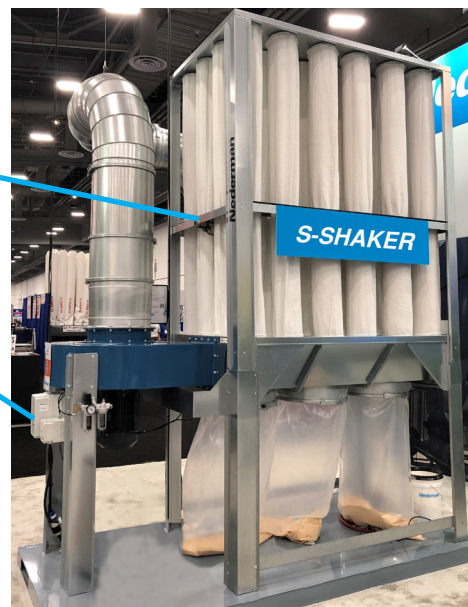

Shaker Plate



Automatic Controls

Models & Specifications

Model	Part Number	Actuator Style	Pneumatic Cylinder	Voltage (v) @60 Hz	Compressed Air Supply
S-500	89101071	Manual	---	---	---
	89101072	Mechanical	Included	N/A	0.5 SCFM @ 90 psi 3/8" NPT (min)
	89101073	Automatic	Included	208-230/460 V / 3 Phase	0.5 SCFM @ 90 psi 3/8" NPT (min)
	89101074	Automatic	Included	575 V/3 Phase	0.5 SCFM @ 90 psi 3/8" NPT (min)
S-750 / S-1000	89101075	Manual	---	---	---
	89101076	Mechanical	Included	N/A	0.5 SCFM @ 90 psi 3/8" NPT (min)
	89101077	Automatic	Included	208-230/460 V / 3 Phase	0.5 SCFM @ 90 psi 3/8" NPT (min)
	89101079	Automatic	Included	575 V/3 Phase	0.5 SCFM @ 90 psi 3/8" NPT (min)

Notes:

1. Automatic controller is designed to connect standard Nederman starters. Please see wiring schematics for Interlock Connections.
2. Contact Nederman for 575 V power supply options.
3. Compressed air to be dry and oil free (ISO 8573-1: Class 4 for conditioned interior installation, Class 3 for installation with possible risk of frost). Supply pipe should be 1/2" diameter or larger.

Real World Results

A recent study at a woodworking factory in Charlotte, NC, USA produced these findings after the installation of shaker option:

- Up to 40% reduction in filter pressure drop after filter cleaning
- 8-10% increase in suction power improving dust capture
- Consistent and effective cleaning results
- Less operator attention and cleaner waste bag change-outs

"The extended life of tooling due to improved suction was a major improvement for us."

Engineering Manager in Charlotte, NC, USA
Atlantic Commercial Caseworks

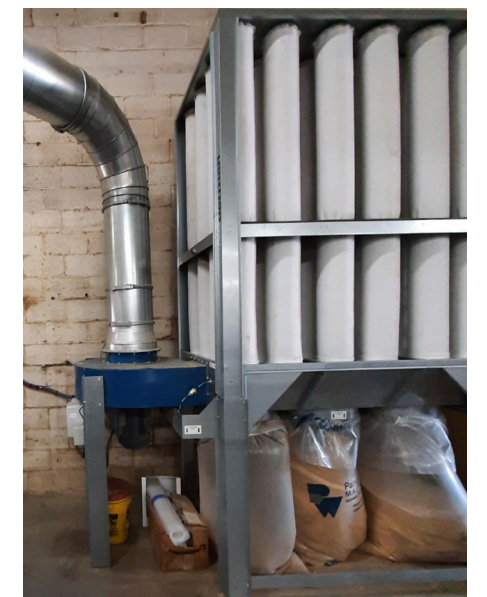

Experience and Competence You Can Trust

With over 10,000 S-Series installations, Nederman is a global leader in dust collection solutions



The Nederman Advantage

As the world's largest provider of industrial air pollution control equipment, Nederman is your total solution provider for controlling woodworking dust. No matter the size, complexity or operational requirement, Nederman assesses each customer's unique needs.

- **Proven solution** - With thousands of S-Series installations, we have the expertise and experience to solve your dust collection challenges.
- **Effective** - 99.9% efficient in filtering wood, paper and plastic dust applications with the use of proprietary SuperBag technology.
- **Upgradable** - Can be updated to take advantage of automatic shaker cleaning options with modular components for turn-key installation on new or existing S-Series units.
- **Sustainability** - Energy efficient operation, extended filter life and effective recovery of waste material to be reused or recycled.
- **Low operational cost** - Prolonged filter life, low pressure losses and efficient filter cleaning reduce operating expenses.
- **Regulatory compliance** - Air quality and combustible dust regulations are becoming increasingly stringent. The S-Series is NFPA compliant for indoor operation.

The global leader in complete dust collection solutions

For over 80 years, Nederman has developed products and solutions to reduce the strain on the environment and protect people from the harmful effects of indoor air pollution including dust, smoke, oil mist and gases. We have extensive experience in creating safe working environments, handling combustible dusts, managing turn-key projects and servicing dust collectors. Our innovative, smart solutions including Insight have further strengthened our ability to deliver clean air to our customers throughout the world.



Worldwide presence

Nederman has a strong global presence in both sales and production. We have our own sales companies and distributors in 50 countries. Manufacturing is performed in 13 countries on five continents. In many countries, we also have a well-established service organization. By offering advanced service with high availability, Nederman helps customers to secure continuous, optimized production.



Nederman



The Clean Air Company

Nederman is an environmental technology company and a global leader in industrial air filtration dedicated to capturing, measuring, controlling and cleaning air to make industrial production more efficient, safe and sustainable. Based on industry leading products, solutions and services in combination with innovative IoT technology, we deliver knowledge and facts needed to optimize performance and guarantee emissions compliance to protect people, planet and production.

We specialize in fume extraction, dust collection, combustible dust, exhaust extraction, oil mist filtration and industrial housekeeping. Our offering encompasses everything from design to installation, commissioning and service, combined with state-of-the-art digital technology. We deliver Clean Air Optimised with focus on energy use, process efficiency, health and safety and compliance. This is how we advance our mission to shape the future for clean air.

Your Nederman Distributor:

Nederman Corporation (800) 522 5286 www.nederman.com